

Battery Box in a compact design



Lithium- Battery Pack with a protection electronics (PCM single cells monitoring), Protects the battery against overcharge, deep discharge and short circuit , Implemented Cell balancing.

Applications

Automotive
Industrial
Sport
Medical
and others



UN 38.3 Tested

OEM / ODM service & customized logo available

Pack Specifications	
Nominal Voltage	14.4 V
Capacity (Nominal)	15400 mAh
Energy	222 Wh
Weight	1560 grams
Size (L x W x H) mm	167 x 100 x 78.5 ±1

Operating Specifications	
Operating Voltage	16.8 V to 12.0 V
Charge Voltage	(Max. 16.80 V)
Discharge End Volt.	12.0V
Operating Temperature:	
Discharge	-20°C to 60°C
Charge	0°C to 45°C
Max Discharge Current	15 A (Continuous) 35 A (Peak)
Max Charge Current	10A

Storage Specifications	
Storage Temperature	1 year : -20~25°C(1*)
Relative humidity (45-75%)	3 months : -20~45°C(1*)
	1 month : -20~60°C(1*)
Please refer to Page 2 of this document for Battery Pack discharge characteristics.	

Note (1): If the cell is kept as ex-factory status (50% of charge), the capacity recovery rate is more than 80%.

Standard charging method

0.5C CC (constant current) charge to 16.80V, then CV (constant voltage 16.80V) charge till charge current decline to $\leq 0.02C$

Transportation

The transport of this battery should be noted that this is a lithium battery with more than 100 Wh (dangerous goods class 9 / UN3480 / packing group II, ADR / RID, IATA DGR, IMDG). During transport, do not subject the Batteries or the box(es) to violent shaking, bumps, rain and direct sunlight. Keep the cell(s) at a half-charged state.

Care and safety recommendations:

Never open, short circuit or put in fire. Do not install backwards. Avoid short circuit with metal objects.

ATTENTION:

Improper handling may result in fire, personal injury or product failure due to leakage or Explosion. Use only the charger specified for this battery type. Improper use will reduce considerably the battery life. Please pay attention to following recommendations:

1. Always avoid Deep discharge of the battery
2. Charge the battery before longer Storage.
3. Use only the battery charger specified for this battery type.
4. Do not leave battery in charger over 24 hours.
5. Keep it in a cool and dry place.
6. Avoid exposure to high temperatures.
7. Do not disassemble or modify the battery, may cause the battery to generate heat, explode or ignite.
8. Dispose properly used batteries. Dispose it according to the applicable recycling regulations. Contact your city recycling coordinator. Thank you.

Mechanical specifications

AccuPower Lithium Technology Designed for Demanding Applications

Battery Box Dimensions

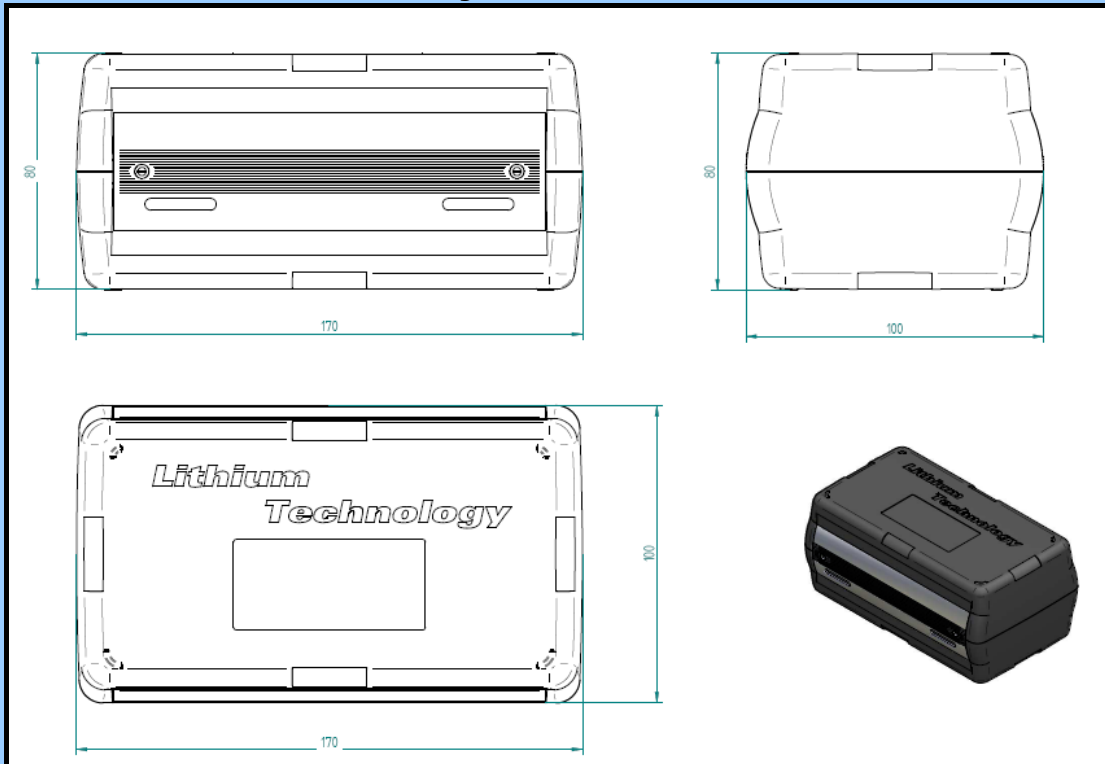

Battery Box with Holding down device

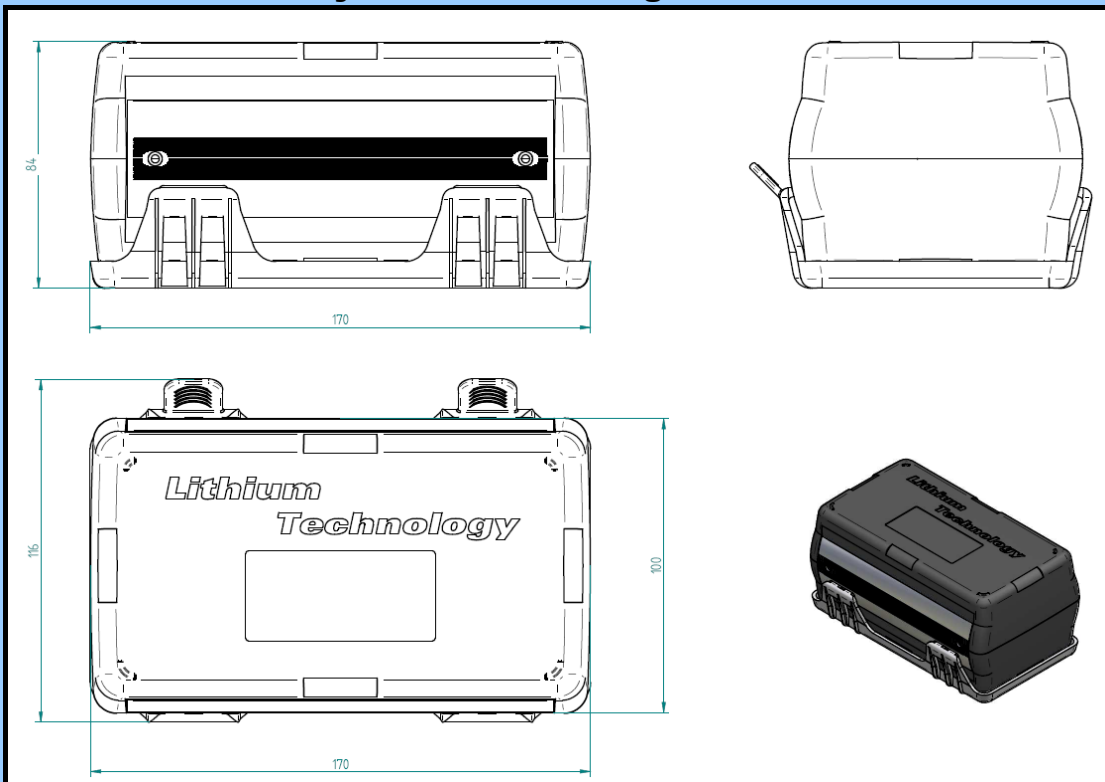

The Battery Box is fabricated from a durable Plastic material for optimal resistance to shock, vibration and resistance to mechanical stress. robust construction, snap-fit screwless assembly

OEM / ODM service & customized logo available

Holding down device work with snapping locking-system

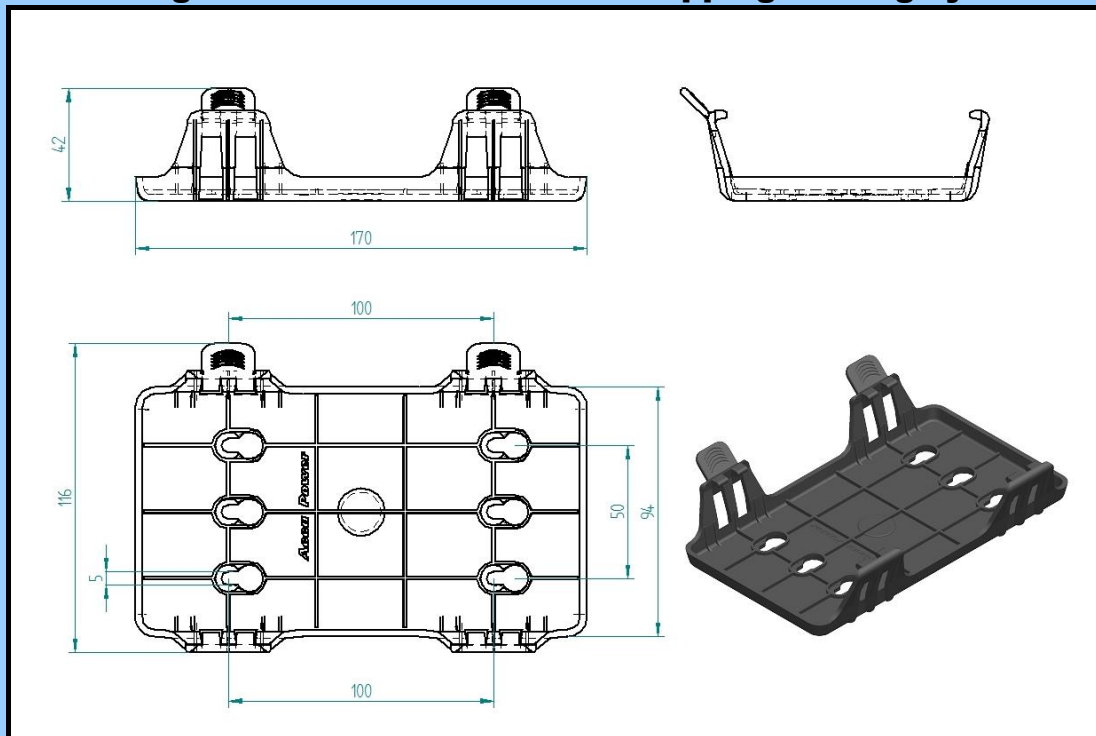

OEM / ODM service & customized logo available

the pictures show how to fixing the battery on holder

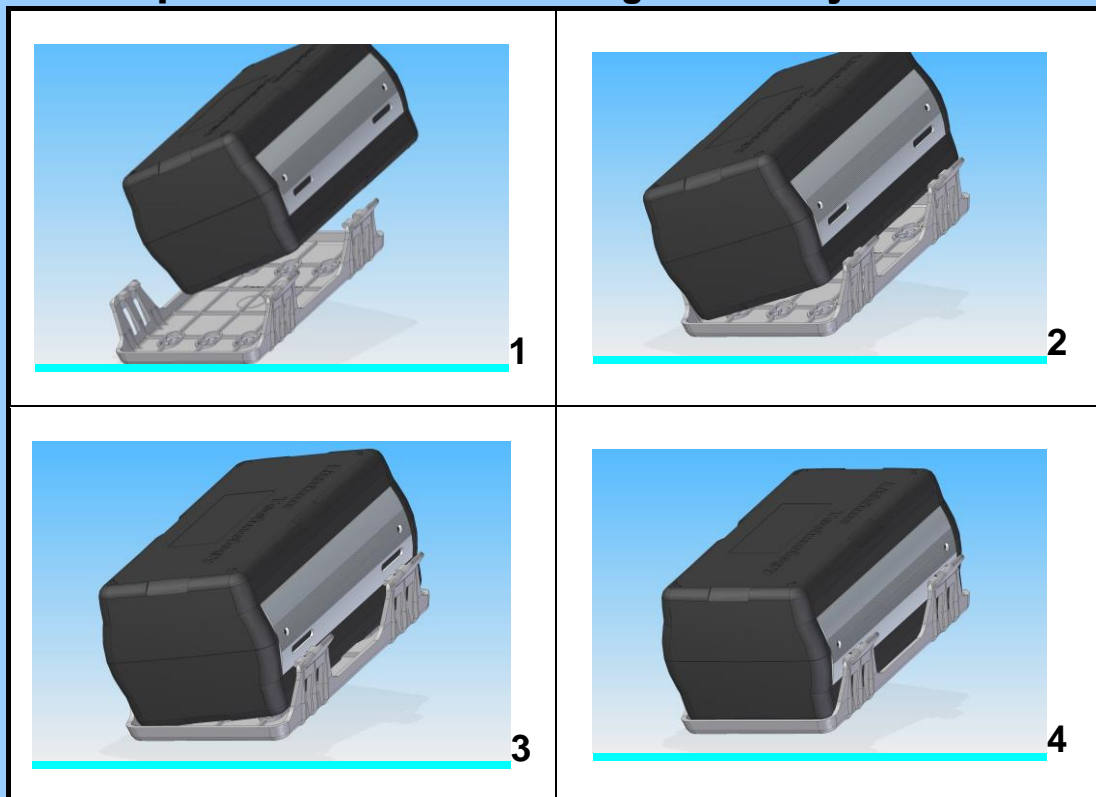

The Holder is optional and not included!!

AccuPower is offering an OEM/ODM service - where customers can customize their own design.